

# DH20/22 DIGITAL TELEPHONE HYBRIDS

## TABLE OF CONTENTS

SECTION 1	INTRODUCTION	4
	WHAT IS A HYBRID?	4
	DH20/22 FEATURES	5
	WHAT COMES WITH THE DH20/22?	5
	PRODUCT REGISTRATION AND TECHNICAL SUPPORT	5
SECTION 2	PRODUCT DESCRIPTION	6
	DH20/22	6
	TELEPHONE SEPARATION (NULL)	6
	AUTOMATIC GAIN CONTROL	6
	AUTOMATIC MIX-MINUS	6
	CALLER CONTROL	6
SECTION 3	DIAGRAMS AND DESCRIPTIONS OF CONTROLS AND CONNECTORS	7
	FRONT PANEL CONTROLS	7
	REAR PANEL CONNECTORS	9
SECTION 4	INSTALLATION	10
	TELEPHONE LINE REQUIREMENTS	10
	INSTALLATION EXAMPLES	10
	POWER CONNECTION	12
	REMOTE CONTROL	12
	AUDIO CONNECTIONS	12
	TELEPHONE LINE CONNECTIONS	12
SECTION 5	MIX-MINUS	13
	USING THE MIC PREAMP	13
	USING THE DIRECT MIC OUTPUT OF THE CONSOLE	14
	USING A DISCRETE MICROPHONE MIXER	14
	USING AN INTERNAL MIX BUS (TELEPHONE MODULE)	15
	USING A SEPARATE MIX OUTPUT BUS FROM THE CONSOLE	15
	USING A SEPARATE AUXILIARY OUTPUT BUS FROM THE CONSOLE	16
	USING THE STEREO OUTPUTS OF THE CONSOLE	16
SECTION 6	CALIBRATION	17
	DIP SWITCHES	17
	TRIM POTS	20
	TRAINING THE TELEPHONE ECHO CANCELLER	21
	TRAINING THE MIX-MINUS	21

## TABLE OF CONTENTS (CONT.)

SECTION 7.....	OPERATION .....	22
	FRONT PANEL .....	22
	USING THE HYBRID .....	22
	USING THE TELEPHONE SET .....	22
	SWITCHING A CALL FROM THE SET TO THE HYBRID.....	22
	SWITCHING A CALL FROM THE HYBRID TO THE SET.....	22
	DISCONNECTING A CALL.....	22
	PLACING A CALL.....	22
	ADJUSTING THE MONITOR OUTPUT LEVEL.....	23
	REMOTE CONTROL OPTION.....	23
	RECORDING OPTION .....	23
SECTION 8 .....	SPECIFICATIONS .....	24
	FRONT PANEL .....	24
	REAR PANEL.....	24
	TELEPHONE TRANSMIT .....	25
	TELEPHONE RECEIVE .....	25
	NULL.....	26
	MIX-MINUS .....	26
	PINOUTS .....	26
SECTION 9.....	BLOCK DIAGRAMS .....	28
	DH20.....	28
	DH22.....	29
SECTION 10.....	COMPLIANCE .....	30
	FCC PART 15 COMPLIANCE .....	30
	FCC PART 68 COMPLIANCE .....	30
	IC COMPLIANCE .....	31
	EUROPEAN COMPLIANCE .....	32

***About Comrex***

Comrex has been building reliable, high quality broadcast equipment since 1961. Our products are used daily in every part of the world by networks, stations, and program producers.

Every product we manufacture has been carefully designed to function flawlessly, under the harshest conditions, over many years of use. Each unit we ship has been individually and thoroughly tested. Most items are available off-the-shelf, either directly from Comrex or from our stocking dealers.

Comrex stands behind its products. We promise that if you call us for technical assistance, you will talk directly with someone who knows about the equipment and will do everything possible to help you.

Our toll free number in North America is 800-237-1776. Product information along with engineering notes and user reports are available on our website at <http://www.comrex.com>. Our E-Mail address is [info@comrex.com](mailto:info@comrex.com).

***Warranty and Disclaimer***

All equipment manufactured by Comrex Corporation is warranted by Comrex against defects in material and workmanship for one year from the date of original purchase, as verified by the return of the Warranty Registration Card. During the warranty period, we will repair or, at our option, replace at no charge a product that proves to be defective, provided you obtain return authorization from Comrex and return the product, shipping prepaid, to Comrex Corporation, 19 Pine Road, Devens, MA 01434 USA. For return authorization, contact Comrex at 978-784-1776 or fax 978-784-1717.

This Warranty does not apply if the product has been damaged by accident or misuse or as the result of service or modification performed by anyone other than Comrex Corporation.

With the exception of the warranties set forth above, Comrex Corporation makes no other warranties, expressed or implied or statutory, including but not limited to warranties of merchantability and fitness for a particular purpose, which are hereby expressly disclaimed. In no event shall Comrex Corporation have any liability for indirect, consequential or punitive damages resulting from the use of this product.

***Copyright Notice***

The Comrex proprietary code and licensed, third party proprietary code residing in and otherwise associated with this product are protected by copyright law and international treaties. Unauthorized reproduction or distribution of this product, or any portion of it, may result in civil and criminal sanctions, and will be prosecuted to the fullest extent of the law.

US Government Restricted Rights - Use, duplication, or disclosure by the US Government is subject to restrictions set forth in subparagraph (c)(1)(ii) of the Rights in Technical Data and Computer Software clause at DFARS (48 CFR) 252.227-7013 or subparagraphs (c)(1) and (2) of the Commercial Computer Software-Restricted Rights clause at FAR (48 CFR) 52.227-19, as applicable.

## SECTION 1.

## INTRODUCTION

### *WHAT IS A HYBRID?*

Simply put, a hybrid is a device that separates send and receive audio on a phone line. While the public switched telephone network utilizes separate channels for audio in each direction of a phone call, these two signals are mixed together before being sent to the end user. This way, only one pair of wires is required from your telephone to the telco central office. To use telephone company terms, the telephone network is a “4 wire” system, while the local loop is a “2 wire” system.

When recording or airing telephone conversations in a studio environment, it’s important that telephone audio be “4 wire.” This is because the audio program usually already contains the audio of the “studio host.” If the telephone audio also contains some of the “studio host,” these two signals will be added together by the mixing console. The effect will be distortion in the voice of the “studio host.” In essence, a hybrid converts the “2 wire” telephone line back into a “4 wire” audio path.

It seems counter-intuitive, but the main goal of a studio hybrid is to make the people in the studio sound better. If the hybrid isn’t working well, people speaking from the studio will sound “hollow” or like they’re “talking into a barrel.” This is due to the strange effect of mixing microphone audio with telephone “bleed-through.” Of course, our hybrids also improve the audio of callers, filtering out hum and noise as well as adjusting levels between loud and soft speakers.

It’s our opinion that with the advent of cheap telephones, cordless phones and cellphones, telephone audio has gotten decidedly worse in recent years. While a hybrid can cleanup noise to some extent, it can’t remove distortion caused by the far end telephone. If you find some calls sound good on air and some don’t, it’s probably due to the large disparity in audio quality of today’s telephone sets.

The DH20 and the DH22 digital telephone hybrids will help bring uniformity and high quality sound to a broadcast talk show environment. These digital hybrids provide a telephone interface between a telephone line and audio equipment.

The DH20 and DH22 use digital signal processing (DSP) technology to continually adapt to telephone-line conditions — providing consistent high-quality sound and send to caller separation. The DH20 is a single digital hybrid, allowing connection of one telephone line for on-air use. The DH22 is a dual digital hybrid, allowing the connection of two telephone lines for on-air use. When connected in accordance to United States, Canada, United Kingdom and mainland Europe compliance standards, the digital hybrids are perfect for your telephone application.

*DH20/22 FEATURES*

- ◆ Crystal clear, consistent audio quality
- ◆ Continual adaptation to telephone line conditions
- ◆ Selectable automatic mix-minus and caller automatic gain control (AGC)
- ◆ 1W power amp with volume control on front-panel
- ◆ Selectable mic/line level input
- ◆ On/Off control via front panel and rear panel remote connection
- ◆ Analog receive filter for telephone line noise reduction
- ◆ Selectable caller control (ducking)
- ◆ Balanced inputs and outputs
- ◆ Auxiliary output for recording
- ◆ Simple installation and operation
- ◆ Adjustable send/caller audio level control
- ◆ Selectable single-ring auto-answer and auto-disconnect

*WHAT COMES WITH THE DH20 OR DH22?*

Ensure that the following items were received with your shipment:

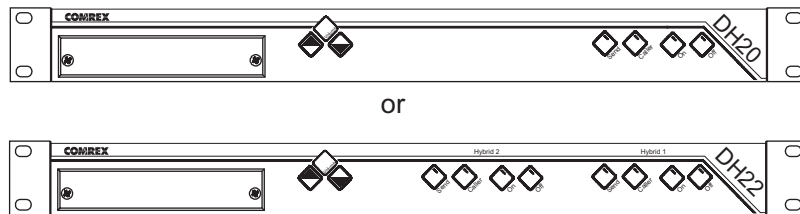

or

(Domestic, Pan European or Australian)



7-foot Modular Telephone Cord



DH20/22 Product Manual

*PRODUCT REGISTRATION AND TECHNICAL SUPPORT*

Please register your DH20/22 by filling out and returning the enclosed warranty registration card or by visiting [www.comrex.com/warranty.htm](http://www.comrex.com/warranty.htm). When your product is properly registered, Comrex can better serve you should you require technical assistance or need upgrades or new product information. If you have any problems or simply need a question answered, please call us at 978-784-1776. Our toll free number in North America is 800-237-1776. Product information along with engineering notes and user reports are available on our website at [www.comrex.com](http://www.comrex.com). Our email address for technical support is [techies@comrex.com](mailto:techies@comrex.com).

---

**SECTION 2.**

**PRODUCT DESCRIPTION**

*DH20/22*

The DH20 and DH22 provide superior analog telephone integration into broadcast applications. With a variety of selectable functions from the front panel DIP SWITCHES, these digital hybrids can be customized to meet your specific needs. By continually adapting to telephone line conditions and isolating send audio from caller audio, the DH20 and DH22 produce clean, consistent audio. Both hybrids offer a built-in mix-minus feature for installation when no mix-minus facilities are available through the console.

*DH22*

The DH22 is a dual hybrid unit designed for conferencing two telephone lines. The DH22 has all the same features as the DH20 but can handle two callers at the same time. The two internal hybrids contain a common send audio input and the two telephone lines are internally conferenced. This means two callers can be on-air at once. Both callers' audio can be combined as a single input on your console or as two separate outputs to two console inputs.

*TELEPHONE SEPARATION  
(NULL)*

Using Digital Signal Processing (DSP) technology and firmware, the interface between a standard analog POTS line and your audio equipment will result in superior quality audio. The primary function of the DH20 and DH22 hybrids are to maximize the null by maximizing the separation of send and caller audio. Both hybrids provide >55dB null between 250Hz to 3.5kHz.

*AUTOMATIC GAIN CONTROL  
(AGC)*

AGC normalizes the gain of caller audio, augmenting the level of "soft" callers, and attenuating the level of "loud" callers. This helps provide more uniform caller audio levels at the caller output of the hybrid. The AGC threshold is -50dBm. The AGC works to achieve an equivalent average caller level of -30dBm from the telephone circuit.

*AUTOMATIC MIX-MINUS*

The DH20 and DH22 auto mix-minus creates a mix-minus for the hybrid when one is not available from the audio console. See the "Mix-Minus" section on pages 13-16 for additional information.

*CALLER CONTROL*

Caller control, also known as ducking, attenuates the caller input audio when send audio is present. The purpose of this attenuation is to allow the talent to dominate their conversation with the callers. The amount of caller control (attenuation) applied to the caller audio is selectable from 0 to 18dB, in 6dB increments.

## SECTION 3.

## DIAGRAMS AND DESCRIPTIONS OF CONTROLS AND CONNECTORS

## FRONT PANEL CONTROLS

DH20 Front Panel Controls

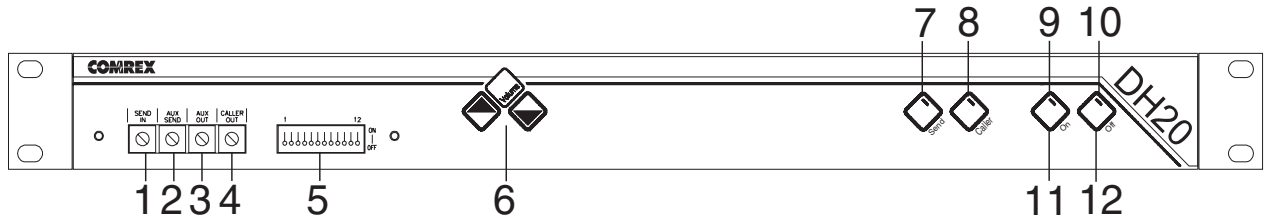

DH22 Front Panel Controls

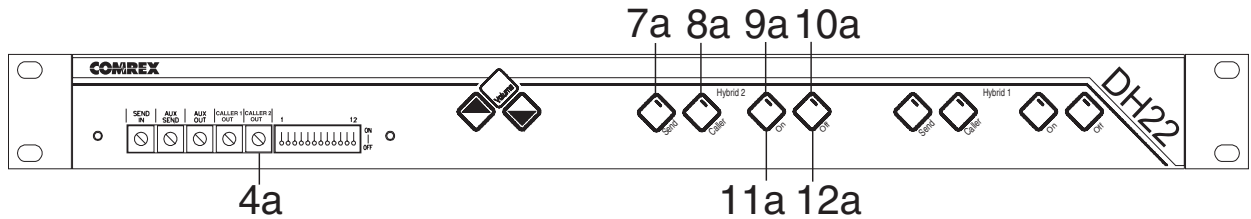

- 1) *SEND IN* This trim pot adjusts the level of audio sent to the phone line via the SEND IN jack. At its midpoint (6 o'clock position), this trim pot is set for nominal send level (0dBu).
- 2) *AUX SEND* This trim pot adjusts the level of the auxiliary send audio coming from the REMOTE connector input and going onto the telephone line to the caller. At its midpoint (6 o'clock position), this trim pot is set for nominal level (0dBu).
- 3) *AUX OUT* This trim pot adjusts the level of the audio at the AUX OUT jack. At its midpoint (6 o'clock position), this trim pot is set for nominal level (0dBu).
- 4) *CALLER OUT* This trim pot adjusts the caller audio level to the user's equipment. At its midpoint (6 o'clock position), this trim pot is set for nominal caller level (0dBu).
- 4A) *SECOND CALLER OUT* The DH22 has a second CALLER OUT trim pot for hybrid 2.
- 5) *DIP SWITCHES* These switches configure the hybrid's system. Individual switch functions are defined in the "Calibration" section, starting on page 17.
- 6) *VOLUME* These up/down buttons control the audio level of the monitor out speaker amplifier. Pressing a button once changes the level by 1dB. Pressing and holding a button sweeps the level up or down.
- 7) *SEND LED* This bi-color LED indicates the relative level of the send audio into the digital hybrid. Green indicates nominal level, amber indicates caution and red indicates clipping.

- 7A) *SECOND SEND LED*      The DH22 has a second SEND LED for hybrid 2.
- 8) *CALLER LED*      This bi-color LED indicates the relative level of the caller audio from the telephone line. Green represents nominal level, amber indicates caution and red indicates clipping.
- 8A) *SECOND CALLER LED*      The DH22 has a second CALLER LED for hybrid 2.
- 9) *ON LED*      This LED indicates that the DH20/22 has connected with the phone line. The LED illuminates green when the hybrid is on and flashes green when the phone line is ringing.
- 9A) *SECOND ON LED*      The DH22 has a second ON LED for hybrid 2.
- 10) *OFF LED*      This LED indicates the hybrid is not connected to an active phone line. The LED illuminates red when the hybrid is off.
- 10A) *SECOND OFF LED*      The DH22 has a second OFF LED for hybrid 2.
- 11) *ON SWITCH*      The ON switch connects the hybrid to the telephone line.
- 11A) *SECOND ON SWITCH*      The DH22 has a second ON switch for hybrid 2.
- 12) *OFF SWITCH*      The OFF switch disconnects the hybrid from the telephone line and mutes all audio going to and from the telephone line.
- 12A) *SECOND OFF SWITCH*      The DH22 has a second OFF switch for hybrid 2.



## REAR PANEL CONNECTORS

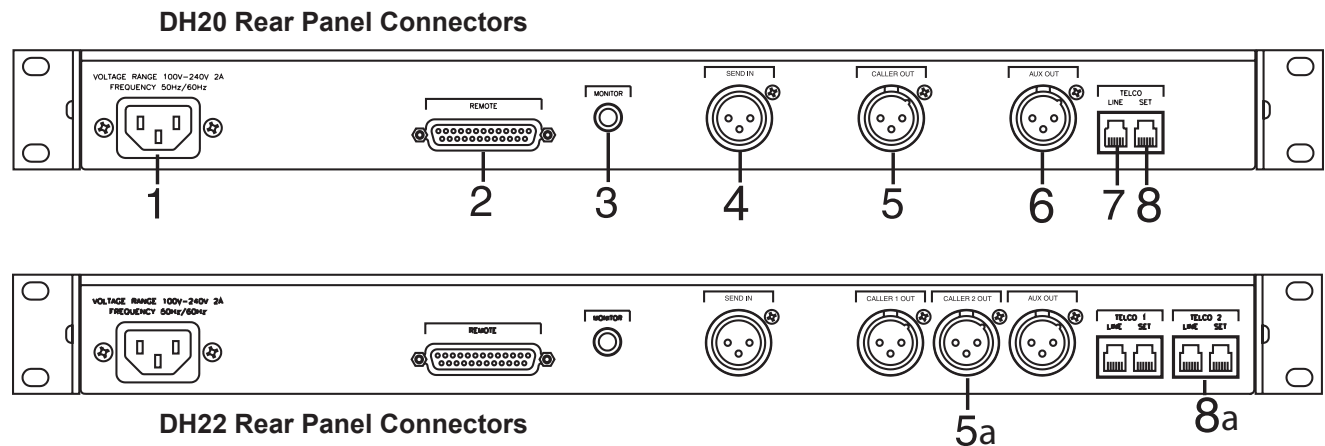

- 1) **POWER**                      The AC power cord input is an IEC type connector allowing use of premolded domestic US power cords as well as various other premolded international power cords.
- 2) **REMOTE**                      This DB25 female connector provides remote control and status of the hybrid. Unbalanced send in, caller out and aux out audio are also available at the REMOTE connector. See “Pinouts” on page 26.
- 3) **MONITOR OUT**              This 1/4” jack is a speaker connection for monitoring the caller audio signal. The monitor output provides 1 Watt into an 8 Ohm speaker.
- 4) **SEND IN**                      This balanced, female, 3-pin XLR input receives audio from the source (microphone or mixer) and sends it to the caller. *Note: if using a single microphone that needs phantom power to operate, you must supply this power to the microphone. The digital hybrid does not supply phantom power.* Audio sent to the caller must be a mix-minus. (See the “Mix-Minus” section on pages 13-16.)
- 5) **CALLER OUT**                This balanced, male, 3-pin XLR output contains the audio from the caller.
- 5A) **SECOND CALLER OUT**      The DH22 has a second CALLER OUT for hybrid 2.
- 6) **AUX OUT**                      This balanced, male, 3-pin XLR output contains a mix of caller and send audio or caller audio only. (See “DIP Switches” on pages 17-19.) This connector can feed a recording device to record both the caller and send audio.
- 7) **LINE**                          This RJ11 connector provides connection of the telephone line to the hybrid. A-Lead closure is provided (see page 27 for further details).
- 8) **SET**                            This RJ11 connector allows connection to a standard analog telephone set. The telephone line is present at this connector when the hybrid is off. The telephone line is not present at this connector when the hybrid is on. A-Lead closure is provided (see page 27 for further details).
- 8A) **SECOND SET**                The DH22 has a second LINE and SET pair for hybrid 2.

## SECTION 4. INSTALLATION

### TELEPHONE LINE REQUIREMENTS

The DH20/22 operates on a standard POTS (plain old telephone service) analog telephone line or an analog extension from a PBX via a standard RJ11 modular jack. *Note: Some telephone lines do not provide battery voltage (dry line, no DC offset voltage). If yours does not, the DH20/22 may be configured by qualified personnel for dry line operation. Please contact Comrex Technical Support for details.*

### INSTALLATION EXAMPLES

The hybrids are designed for easy installation and set up. All necessary interface connections are made through rear panel connectors. Refer to “Rear Panel Connectors” on page 9 for a description and placement of each of the connections you will be making.

The diagram below illustrates typical hybrid connections for the DH20. To install your hybrid, make the following connections:

### Typical DH20 Installation

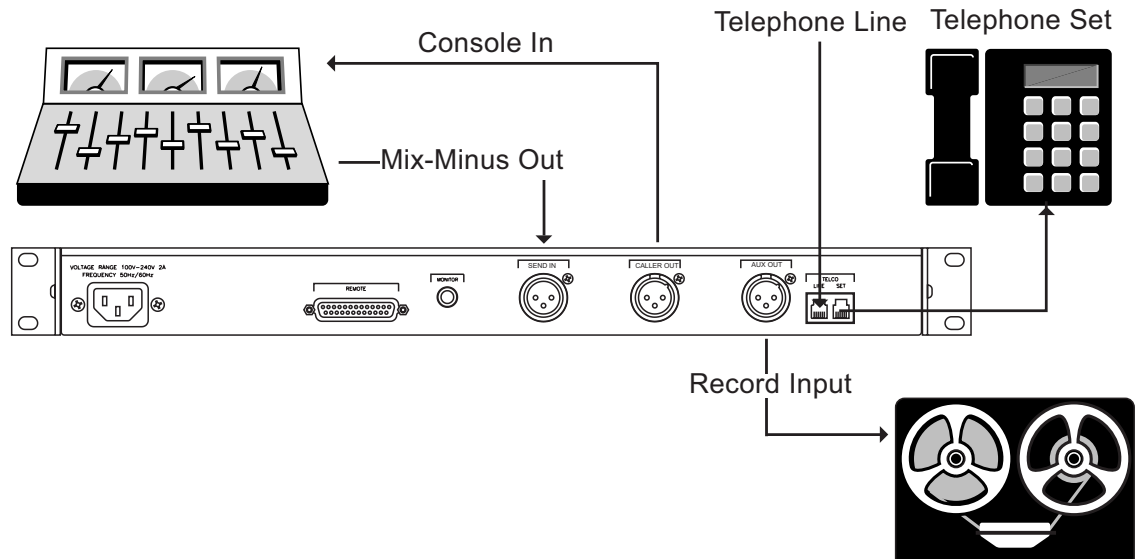

The diagrams below illustrate typical hybrid connections for the DH22:

**Typical DH22 Installation — Independent Callers**

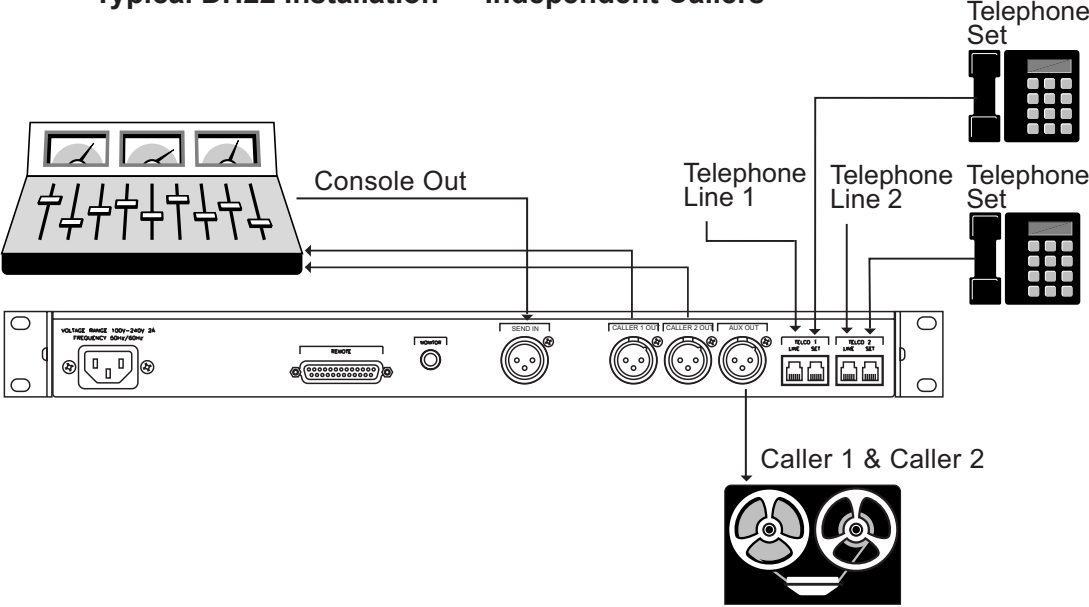

(See page 19 for setting DIP SWITCH 11 which enables/disables **Caller Mix**)

**Typical DH22 Installation — Callers Mixed**

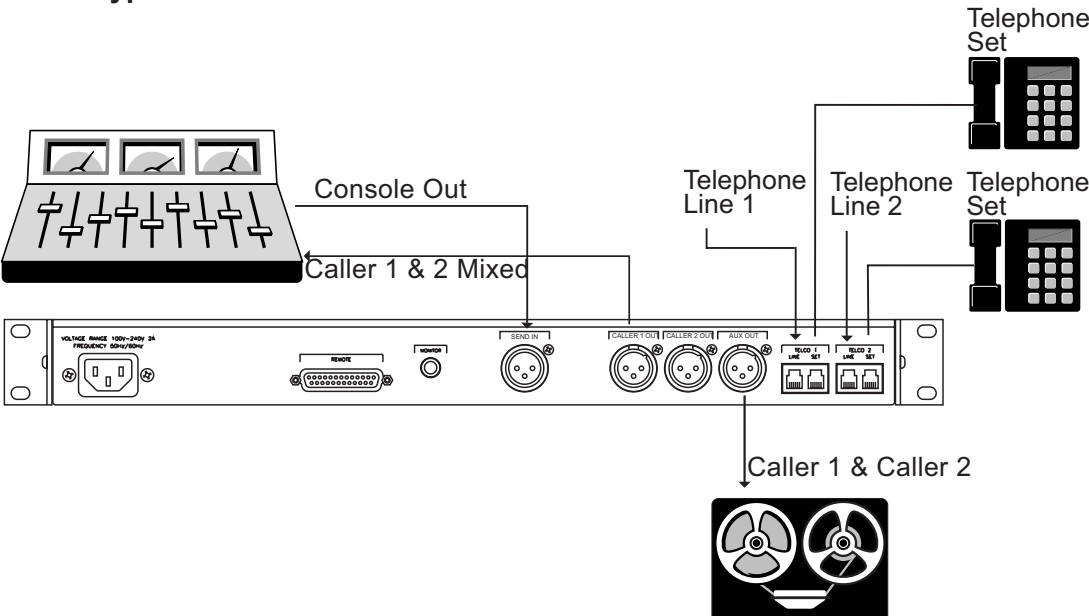

**POWER CONNECTION**

The DH20/22 will operate with any power source between 100-240VAC, 50/60Hz.

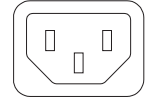

**REMOTE CONTROL**

If using a remote control for parallel control and hybrid status, use the DB25 REMOTE connector. For “Pinouts,” see page 26.

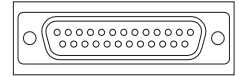

**AUDIO CONNECTIONS**

**Monitor Out** — This 1/4” TRS jack provides a 1W amplified caller signal into an 8 Ohm speaker.

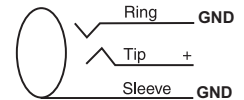

**Send In** — Connect the SEND IN female XLR jack to an output from your studio console. When the hybrid is on, the audio connected to this input will be fed onto the phone line. Audio sent to the telephone line must be a mix-minus. See the “Mix-Minus” section on pages 13-16.

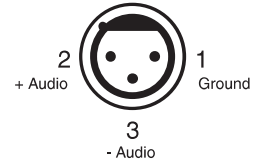

**Caller 1 and 2 Out** — Connect the CALLER OUT male XLR jack(s) to the input(s) on your audio console. When the hybrid is on, this output will contain the audio coming from the caller(s). The DH22 caller out audio may be configured for a mix of caller audio on CALLER 1 OUT or independent caller audio on CALLER 1 OUT and CALLER 2 OUT. See “DIP Switches” on pages 17-19.



**Aux Out** — Connect this male XLR jack to your recording device. The AUX OUT can be configured to contain a mix of send audio and caller audio or caller audio only. See “DIP Switches” on pages 17-19.



**TELEPHONE LINE CONNECTIONS**

**Telco 1 Line** — Plug your analog telephone line into the RJ11 LINE jack.

TELCO 1  
LINE SET

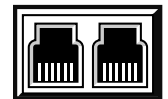

**Telco 1 Set** — Plug your telephone set into the RJ11 SET jack.

**Telco 2 Line (For DH22)** — Plug your second analog telephone line into the RJ11 LINE jack.

TELCO 2  
LINE SET

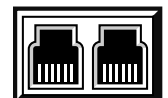

**Telco 2 Set (For DH22)** — Plug your second telephone set into the RJ11 SET jack.

## SECTION 5.

## MIX-MINUS

Mix-minus is a mix of all studio audio sources except caller audio. Without a mix-minus feed from the console, the caller audio sent to the console will be retransmitted to the caller. This can cause hollow sounding audio and can even result in feedback. The diagrams in this section illustrate some of the ways to create/configure an external mix-minus feed for the DH20/22 hybrid.

The internal mix-minus feature in these hybrids can be effective in removing the caller from the outgoing audio feed (the feed being sent back down the phone line). It does have its limitations, however. Because this mix-minus generation works on the same principles as the send-receive separation, changes in program level (e.g. riding a fader on the console) will cause the mix-minus feed to adapt, causing performance issues and audio distortion. The mix-minus generator is also very sensitive to non-linear processing (mic processors or compressor-limiters), so these must be left out of the signal chain. For the same reason, the mix-minus generation will cause severe distortion on over driven audio levels.

In practice, whenever practical, we recommend creation of a true mix-minus feed in the studio rather than engaging this function. We consider this feature useful as a last resort, when no true mix-minus is technically possible. If an external mix-minus cannot be obtained, then activate the DH20/22's internal mix-minus feature. See "DIP Switches" on pages 17-19.

*USING THE MIC PREAMP*

If only microphone audio is being sent to the caller, the internal microphone preamplifier of the hybrid may be used. When doing this, change the SEND IN jack from a line level input to a mic level input by placing DIP SWITCH 4 to the on (up) position.

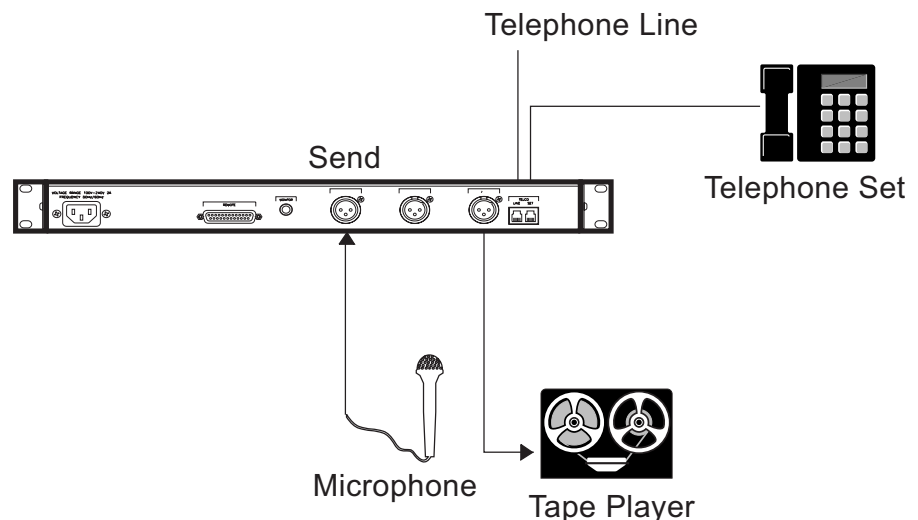

*USING THE DIRECT MIC  
OUTPUT OF THE CONSOLE*

If only microphone audio is being sent to the caller, then it is possible to use the console's direct microphone output. Use the console direct microphone output to provide line level microphone audio to the SEND IN jack of the DH20/22.

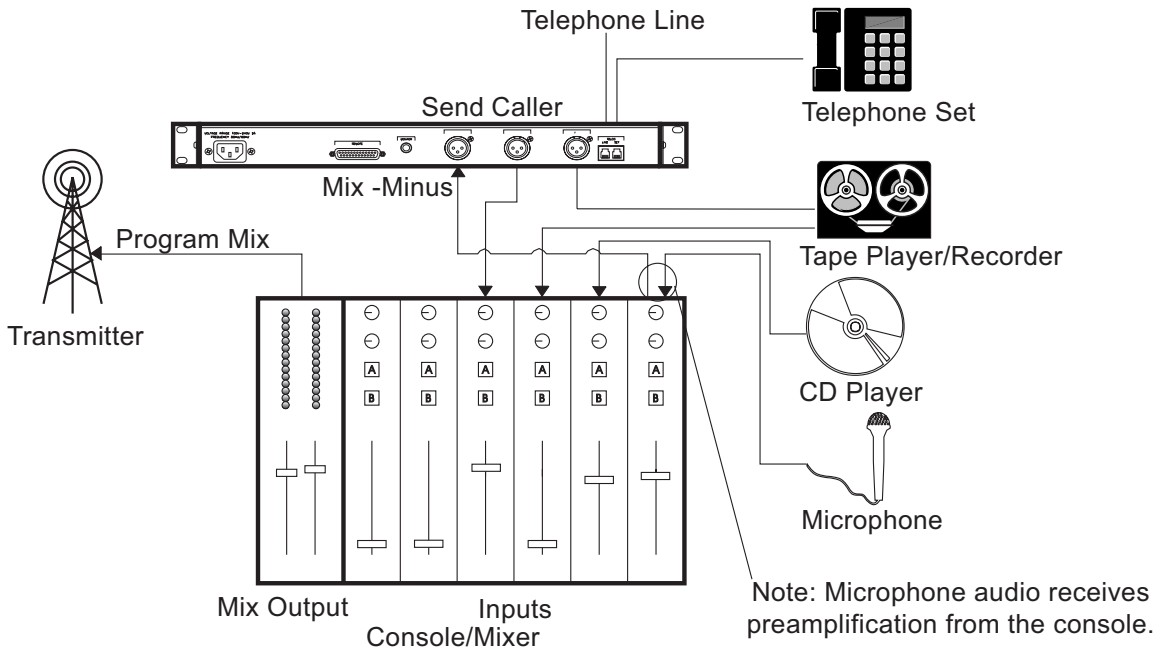

*USING A DISCRETE  
MICROPHONE MIXER*

If only microphone audio is being sent to the caller, a separate microphone mixer may be used. The mic mixer will provide the mix-minus feed for the hybrid, because its output contains no caller audio.

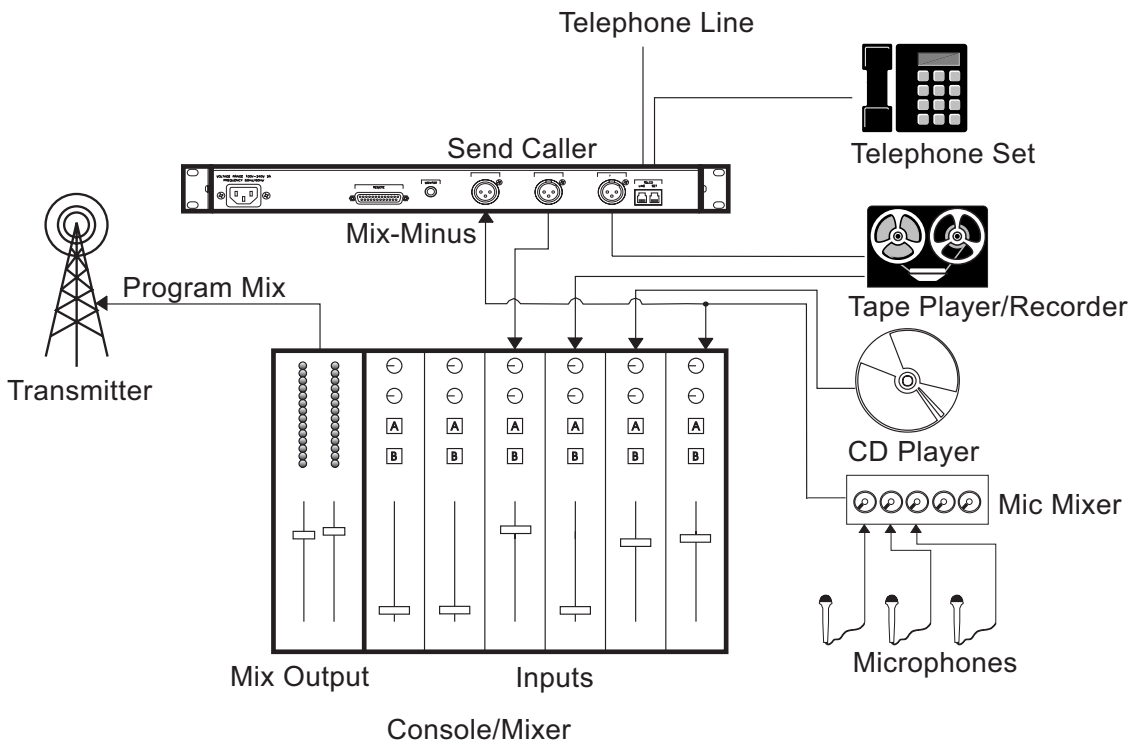

*USING AN INTERNAL MIX BUS (TELEPHONE MODULE)*

Many console manufacturers provide optional telephone hybrid modules for their consoles. These modules are designed to receive audio from a hybrid and transmit audio to the hybrid. A telephone module will create a mix-minus for the hybrid at its output.

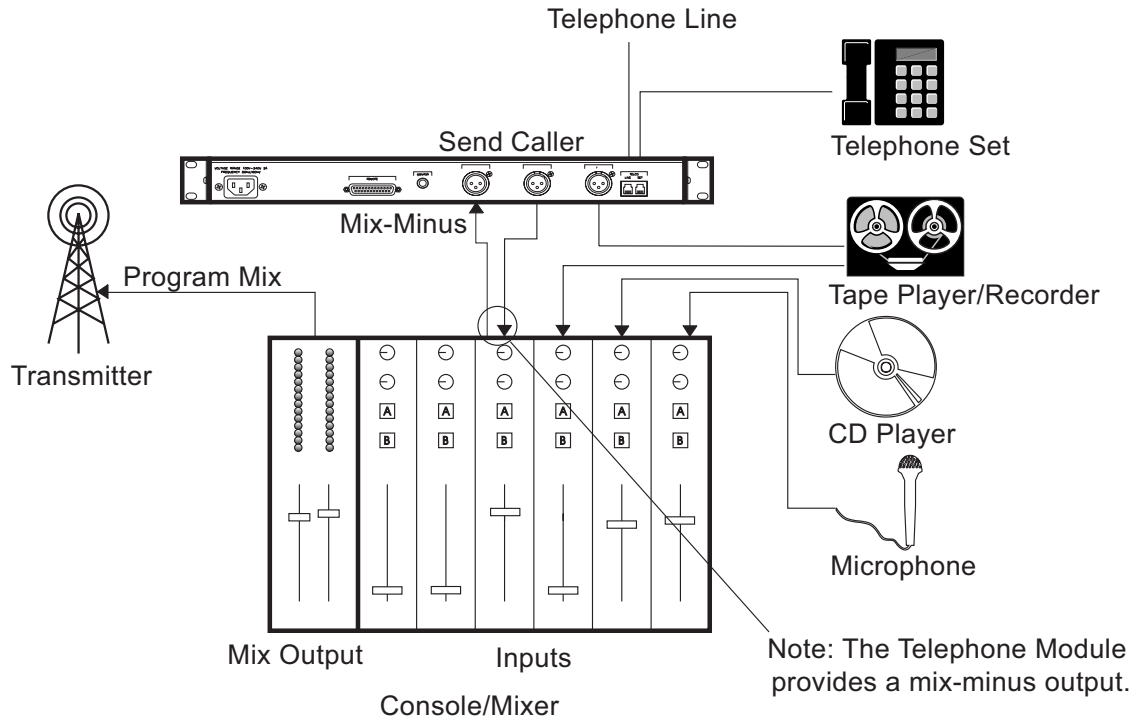

*USING A SEPARATE MIX OUTPUT BUS FROM THE CONSOLE*

If the console has an extra mix output, then use this extra output to provide a mix-minus feed for the hybrid. Simply route all audio, minus the caller audio, to the extra output bus of the console (Output B).

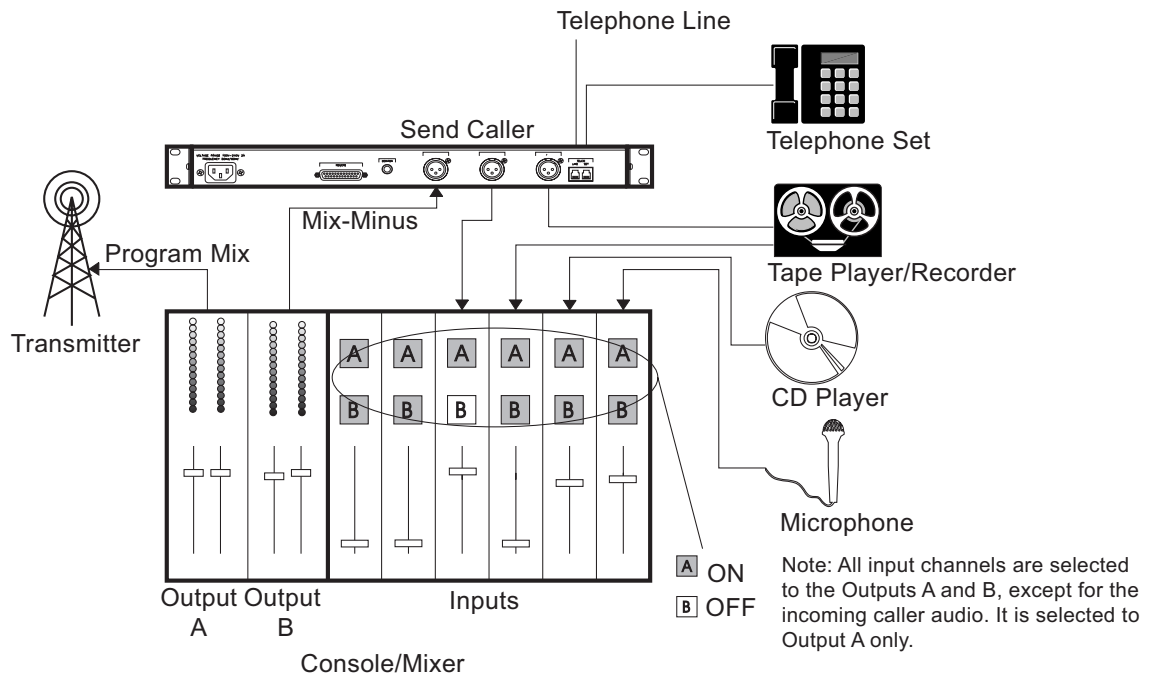

*USING A SEPARATE AUXILIARY OUTPUT BUS FROM THE CONSOLE*

If the console has an auxiliary output, usually called Aux Out or Aux Send, then use this auxiliary output to provide a mix-minus feed for the hybrid. Simply route all audio, minus the caller audio, to the auxiliary output bus of the console.

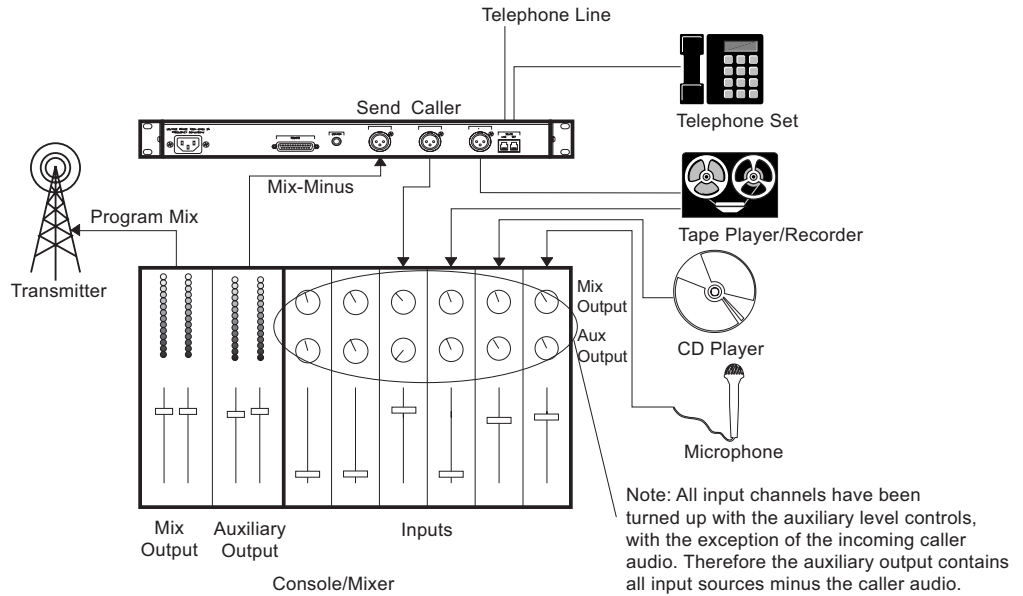

*USING THE STEREO OUTPUTS OF THE CONSOLE*

By using the stereo outputs of the console, it is possible to create a mix-minus for the hybrid. By panning the caller audio to the left channel only, the caller audio is prevented from reaching the right channel output of the console. Therefore, the right channel output is a mix-minus - a mix of all audio minus the caller audio.

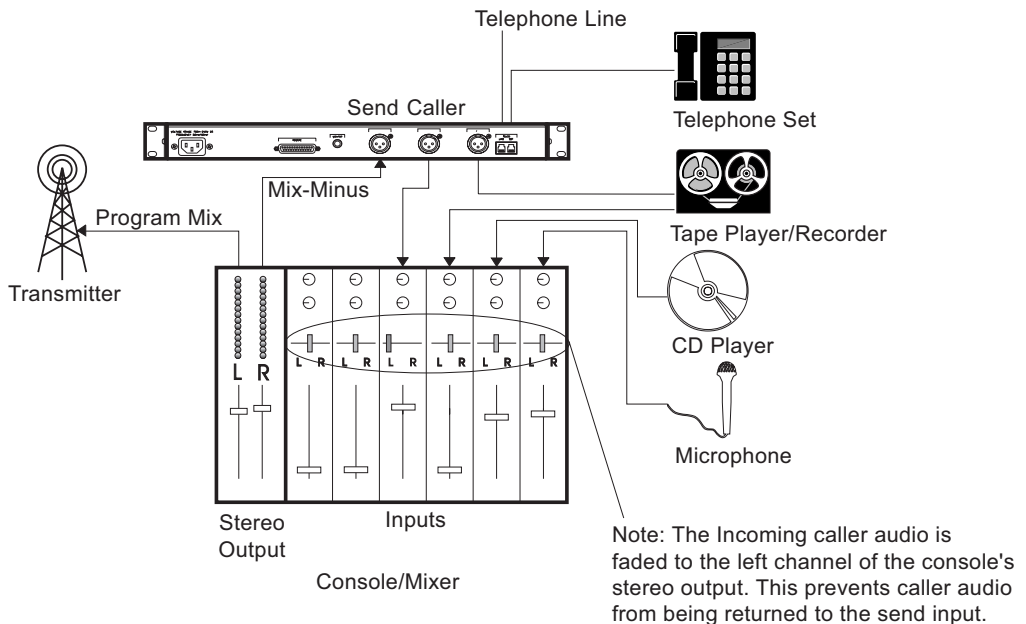



## SECTION 6.

## CALIBRATION

## DIP SWITCHES

DIP SWITCHES are “off” in the down position and “on” in the up position.

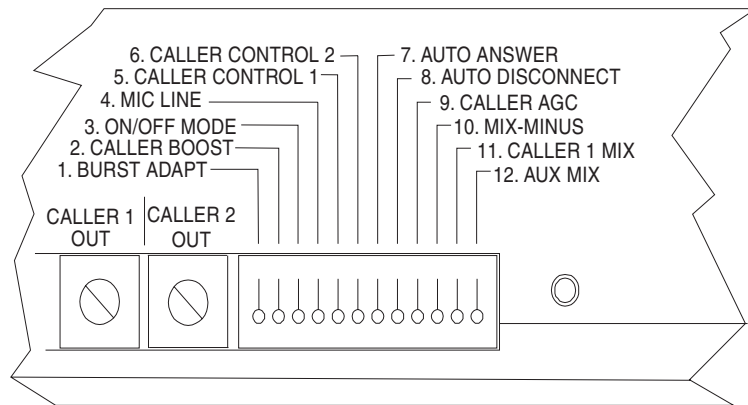

**DIP SWITCH 1** — Enables/disables the **Burst Adapt** feature. In the “off” position (down) the hybrid is in **Auto Adapt Mode**. In the “on” position (up) the hybrid will send a noise burst to the telephone line and aggressively adapt before returning to **Auto Adapt Mode**. Each press of the ON button will generate a new noise burst.

In either mode, the hybrid continually monitors and adapts to the changing telephone line conditions in order to digitally cancel the telephone line echo and provide the best send-to-caller separation possible.

**DIP SWITCH 2** — Enables/disables the **Caller Boost** feature. In the “off” position (down) the caller boost feature is disabled. In the “on” position (up) the hybrid adds 6dB of level boost to the caller’s audio at the CALLER OUT jack.

**DIP SWITCH 3** — Allows the hybrid to work with two types of switches for external (remote) control — momentary and latching. In the “off” position (down) the ON/OFF control inputs respond to momentary closures to ground. This turns the hybrid on when it receives a momentary closure on the ON control input and off when it receives a closure on the OFF control input. In the “on” position (up) the OFF control input is disabled and the ON control input responds to a latching closure to ground. This will cause the hybrid to turn on when the latching switch is closed to ground and the hybrid will remain on until the closure to ground is opened. This DIP SWITCH setting also affects the operation of the front panel ON/OFF buttons. See “Pinouts” (page 26) for REMOTE CONTROL connector pinouts.

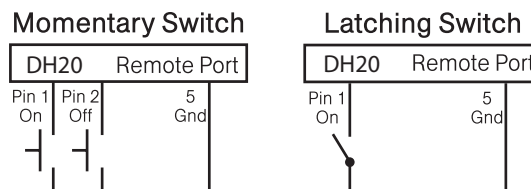

**DIP SWITCH 4** — Sets the gain of the SEND IN jack. In the “off” position (down) the input is a nominal line level (0dBu) input. In the “on” position (up) the input is a mic level providing +55dBu of input gain.

**DIP SWITCHES 5 & 6** — Enables/disables the **Caller Control** (ducking) feature. In the “on” position (up) the hybrid will provide caller control, which is the suppression of caller audio when send audio is present. In the “off” position (down) caller control is disabled. DIP SWITCH 5, when active, adds 6dB of caller control and DIP SWITCH 6, when active, adds 12dB of caller control. If both are active, then the sum of the two DIP SWITCHES is used, and 18dB of caller control is provided.

**DIP SWITCH 7** — Enables/disables the **Auto Answer** feature. In the “off” position (down) the hybrid will not automatically answer the telephone line. In the “on” position (up) the hybrid will automatically answer the telephone line after the first ring.

**DIP SWITCH 8** — Enables/disables the **Auto Disconnect** feature. In the “off” position (down) the hybrid will not automatically disconnect the telephone line. In the “on” position (up) the hybrid will automatically disconnect the telephone line after the caller hangs up. *Note: The telephone line must provide loop drop, loop reversal or call progress signals in order for the **Auto Disconnect** feature to function. Most telephone systems will provide loop drop shortly after the calling party hangs up. Some PBX systems, but not all, will provide either loop drop or call progress tones such as reorder tones or busy signals. The hybrid will detect most of these signals and then auto disconnect the telephone line.*

**DIP SWITCH 9** — Enables/disables the **Automatic Gain Control (AGC)** feature. In the “off” position (down) the AGC feature is disabled. In the “on” position (up) the AGC feature is enabled. When enabled, the AGC feature normalizes the gain of the caller audio, augmenting the level of “soft” callers and attenuating the level of “loud” callers. This helps provide more uniform caller audio levels at the caller output of the hybrid. The AGC works to achieve an equivalent average caller level of -30dBm from the telephone circuit.

**DIP SWITCH 10** — Enables/disables the **Automatic Mix-Minus** feature. In the “off” position (down) the **Automatic Mix-Minus** feature is disabled. In the “on” position (up) the **Automatic Mix-Minus** feature is enabled. When **Automatic Mix-Minus** is enabled, it is not necessary for you to create a mix-minus output with your console/mixer. You can simply feed program audio to the send input of the hybrid, and the hybrid will automatically remove the caller audio from the program mix and prevent it from returning to the caller as echo, which prevents possible feedback. *Note: This option should only be enabled when no mix-minus facilities are available through the console or mixer.*

**DIP SWITCH 11** (DH22 only) — Enables/disables the **Caller 1 Mix** feature. In the “off” (down) position the **Caller 1 Mix** feature is disabled and telephone lines one and two will appear at the CALLER 1 OUT and CALLER 2 OUT XLR connectors respectively. This allows each caller to be routed to a separate input channel of a console or mixer. In the “on” (up) position the **Caller 1 Mix** feature is enabled and telephone lines one and two will be internally mixed by the hybrid and appear at the CALLER 1 OUTPUT. This allows two callers to be routed to a single input channel of a console or mixer. *Note: When **Caller 1 Mix** is enabled, the CALLER 2 XLR is not active.*

**DIP SWITCH 12** — Enables/disables the **Aux Mix** feature. In the “off” (down) position, the AUX OUT and REMOTE AUX OUT will contain caller audio only. In the “on” (up) position the AUX OUT and REMOTE AUX OUT audio will contain a mix of send and caller audio.

*TRIM POTS*

The front panel trim pots provide level adjustments of the SEND IN, AUX SEND, AUX OUT, and CALLER OUT audio connectors. Separate audio level controls let you optimize the audio level(s) of the DH20/22 to match the audio levels required by the interfaced audio equipment.

In order to optimize the audio levels, have someone call the hybrid from another location. Answer the line by pressing the ON button and continue through the level adjustments. Be aware that some suppression and/or echo may be heard while calibrating the audio levels. Disregard it and continue until the end of the procedure. When the hybrid is properly calibrated there will be no echo or suppression.

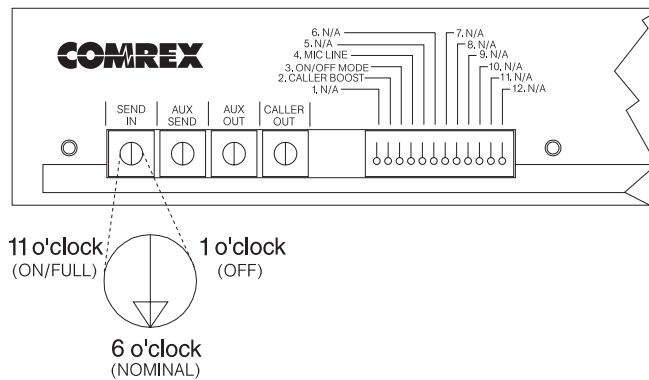

**SEND IN** — This pot adjusts the send in audio. Adjust this pot along with your console audio control until callers verify that the audio level they are receiving is at a comfortable listening level. With comfortable listening levels, the SEND LED should illuminate solid green with an occasional flash of amber on audio peaks. If the SEND LED illuminates red, the audio levels are clipping and should be decreased via the send level adjustments.

**AUX SEND** — This pot adjusts the level of the auxiliary send audio at the REMOTE CONNECTOR input. Adjust this pot along with your console audio control until callers verify that the audio level they are receiving is at a comfortable listening level.

**AUX OUT** — This pot adjusts the level of send and caller audio at the AUX OUT jack. Adjust this pot along with your console audio control to set the proper level for your recording device or other external devices.

**CALLER 1 OUT** — This pot adjusts the caller 1 out audio. Adjust this pot along with your console audio control to set the caller’s voice/audio to a comfortable listening level.

**CALLER 2 OUT** — This pot adjusts the caller 2 out audio. Adjust this pot along with your console audio control to set the caller’s voice/audio to a comfortable listening level.

*Note: The CALLER trim pot has no effect on the CALLER LED. The CALLER LED indicates actual level from the telephone line only. If the CALLER LED flashes green only occasionally with caller audio, the level from the telephone line is too low and you should activate the CALLER BOOST DIP SWITCH. See “DIP Switches” on pages 17-19.*

#### *TRAINING THE TELEPHONE ECHO CANCELLER*

Upon connection to the telephone line, the digital hybrid will automatically begin its telephone echo cancellation process. This will optimize the send to caller separation. If the send to caller separation is not sufficient, you may force the hybrid to “train” itself to the telephone line by pressing and holding the ON button for one second. After one second, the hybrid will emit a burst of white noise. The noise burst allows the hybrid to aggressively adapt to the echo returning from the telephone network and allows the hybrid to maximize its send-to-caller separation.

This noise burst can be generated at any time by pressing and holding the ON button for one second. To force a noise burst on every connection to the telephone line, activate the BURST ADAPT DIP SWITCH 1. See “DIP Switches” on pages 17-19.

#### *TRAINING THE MIX-MINUS*

Upon connection to the telephone line, the digital hybrid will automatically begin its mix-minus echo cancellation processes. To verify/fine tune the calibration of the mix-minus, watch the SEND LED as the caller speaks. If the SEND LED is not lighting or only flashing green on the caller’s audio peaks, then the calibration is already complete. If the SEND LED is lighting solid green on caller audio, decrease the loop gain via the SEND INPUT pot or the console level control and train the telephone echo canceller. As the caller continues to speak, you should notice that the SEND LED will begin to illuminate less and less until it no longer lights green on caller audio. This process may need to be repeated if the desired results are not achieved or if the caller is complaining of excessive echo.

**SECTION 7. OPERATION**

**Front Panel**

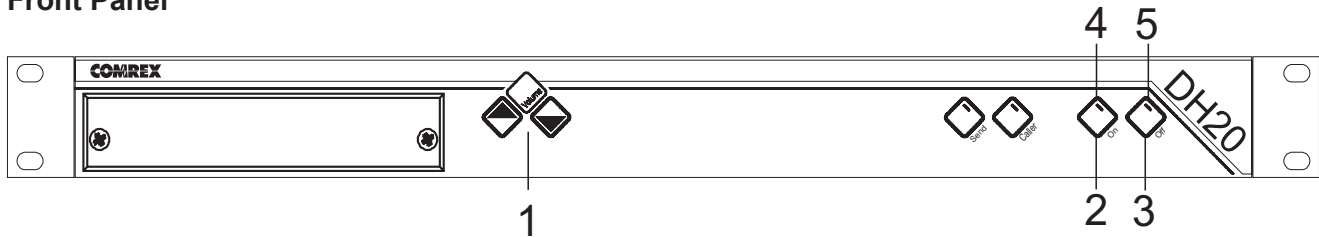

*USING THE HYBRID*

Press the ON button (2) to connect the hybrid to the telephone line. Press the OFF button (3) to disconnect the hybrid from the telephone line. *Note: The ON and OFF buttons do not turn on/off the power to the DH20/22. They connect and disconnect it from the phone line.*

*DH22 users: Ensure that you press the ON or OFF button that corresponds with the hybrid you wish to connect or disconnect. Also, when both hybrids are active in the ON position, telephone callers will be conferenced internally by the DH22.*

*USING THE TELEPHONE SET*

Lift the handset to connect the telephone to the telephone line. Hang up the handset to disconnect the telephone from the telephone line.

*SWITCHING A CALL FROM THE SET TO THE HYBRID*

Press the hybrid's ON button (2). The active call will switch from the phone to the hybrid.

*SWITCHING A CALL FROM THE HYBRID TO THE SET*

Make sure the telephone handset is off hook. Then press the hybrid's OFF button (3). The active call will switch from the hybrid to the phone.

*DISCONNECTING A CALL*

To disconnect the telephone line, the hybrid must be off and the telephone handset must be hung up. If either the hybrid is on or the handset is off hook, then the phone line is still active.

*PLACING A CALL*

Lift the handset and listen for the dial tone. Dial the party you wish to call. Talk to the caller with the telephone set or press the hybrid's ON button (2) to talk through the hybrid. When finished, press the OFF button (3) and/or hang up the handset.

*ADJUSTING THE MONITOR  
OUTPUT LEVEL*

To adjust the level at the monitor output, use the VOLUME buttons (1). With each press, the VOLUME button increases the monitor output level by 1dB. The VOLUME button decreases the monitor output level by 1dB. Pressing and holding the button will sweep the level up or down respectively.

*REMOTE CONTROL OPTION*

The REMOTE CONTROL connector can be used to perform three functions: **Monitor Mute On/Off**, **Hybrid On**, and **Hybrid Off**.

If using a remote control device, internal DIP SWITCH 3 will select the type of button switch function you need (momentary or latching). See page 17 for further details.

DIP SWITCH 3 does not change the operation of the monitor mute input. The monitor output will be muted for as long as the monitor mute input pin is tied to ground.

*RECORDING OPTION*

While on a connected call, a mix of both send and caller(s) audio, or caller(s) audio only, will be routed to the AUX connector. Connect your recording device to this connector. Activate the record function of the external recording device to capture the audio.

## SECTION 8.

## SPECIFICATIONS

### *FRONT PANEL*

#### Controls:

- Hybrid One On Button
- Hybrid One Off Button
- Hybrid Two On Button (DH22)
- Hybrid Two Off Button (DH22)
- Volume Up and Volume Down Buttons

#### Status LED's:

- On Status
- Off Status
- Hybrid One Send Audio Presence
- Hybrid One Caller Audio Presence
- Hybrid Two Send Audio Presence (DH22)
- Hybrid Two Caller Audio Presence (DH22)

#### Adjustments:

- Send Input Level
- Caller One Output Level
- Caller Two Output Level
- Auxiliary Input Level
- Auxiliary Output Level

#### DIP Switches:

- Burst Adapt Selection
- Mic/Line Selection
- Caller Boost Selection
- Momentary/Latching Control
- Auto Answer/Disconnect Selection
- Call Control Selection (0, 6, 12 or 18dB)
- AGC Selection
- Auto Mix-Minus Selection
- Caller One Mix Selection (DH22)
- Aux Mix Selection

### *REAR PANEL*

#### Power: IEC Type

Auto Adjusting, 100-240VAC, 2A, 50/60Hz, 30W

#### Remote: DB25 Female

Send Input — 0dBu nominal, adjustable, unbalanced, 20k Ohm impedance.

Caller and Aux Outputs — 0dBu nominal, adjustable, unbalanced, 50k Ohm impedance.



*REAR PANEL CONTINUED*

**Control Inputs** — Remotely activate any of the following functions with a switch closure to ground: Hybrid 1 ON, Hybrid 1 OFF, Hybrid 2 ON, Hybrid 2 OFF and Monitor Mute.

**Status Outputs** — Remotely check the status and audio presence of the hybrids using the Hybrid 1 and 2 ON, OFF, SEND and CALLER presence status outputs. Status outputs are open collector outputs rated 30VDC and 40mA maximum.

*Monitor Output: 1/4" Stereo Jack*

Tip = + phase, Ring = ground, Sleeve = ground  
1W output into an 8 Ohm load

*Send Input: XLR Female*

Mic/Line selectable, -55/0 dBu nominal, adjustable, balanced bridging, 20k Ohm impedance

*Caller 1 and 2 Outputs: XLR Male*

0 dBu nominal, adjustable, balanced, 50 Ohm impedance

*Aux Output: XLR Male*

0 dBu nominal, adjustable, balanced, 50 Ohm impedance

*Telco 1 and 2 Lines: RJ11 Connector*

POTS (Plain Old Telephone Service) telephone line or analog extension from a PBX or dry line (no DC offset voltage). A-Lead Supervision provided

*Telco 1 and 2 Sets: RJ11 Connector*

A-Lead Supervision provided

*TELEPHONE TRANSMIT*

Nominal send input of 0 dBu referenced to -15 dBm onto the telephone line.  
*Frequency Response:* +/- 1dB from 250 Hz to 3.5 kHz; *Dynamic Range:* >70dB;  
*Distortion:* <0.2%

*TELEPHONE RECEIVE*

Nominal phone line level of -15dBm referenced to caller output of 0dBu.  
*Frequency Response:* +/- 1dB from 250 Hz to 3.5 kHz; *Dynamic Range:* >70dB;  
*Distortion:* <0.2%

*NULL*                      *Send-to-Caller Separation: 55dB*  
*Tail Time: 32 milliseconds*

*MIX-MINUS*                *Caller-to-Send Separation: 50db nominal*  
*Tail Time: 32 milliseconds*

*PINOUTS*                    Remote Connector Pinout:

Pin	Description
1	Remote Hybrid 1 On *
2	Remote Hybrid 1 Off *
3	Remote Hybrid 2 On **#
4	Remote Hybrid 2 Off **#
5	Switch/Indicator Common
6	Hybrid 2 Send Presence Indication **#
7	Hybrid 2 Caller Presence Indication **#
8	N/C
9	Unbalanced Send Audio Input (0dBu nominal)
10	Unbalanced Caller Audio Output (0dBu nominal)
11	Unbalanced Aux Audio Output (0dBu nominal)
12	Monitor Mute Control*
13	Audio Common
14	Hybrid 1 On Indication **
15	Hybrid 1 Off Indication **
16	Hybrid 2 On Indication **#
17	Hybrid 2 Off Indication **#
18	Switch/Indicator Common
19	Hybrid 1 Send Presence Indicator **
20	Hybrid 1 Caller Presence Indicator **
21	Switch/Indicator Common
22	Audio Common
23	Audio Common
24	Audio Common
25	Switch/Indicator Common

\* Remote control provided via contact closure to Switch/Indicator Common

\*\* Remote indicators provided via open collector outputs to Indicator Common (<15V, <39mA)

# DH22 only

**Line Connector Pinout:**

Pin	Description
1	To pin 6 of SET RJ11
* 2	To pin 5 of LINE
3	Tip
4	Ring
* 5	To pin 2 of SET
6	To pin 1 of SET RJ11

**Set Connector Pinout:**

Pin	Description
1	To pin 6 of LINE RJ11
* 2	To pin 5 of SET
3	Ring
4	Tip
* 5	To pin 2 of LINE
6	To pin 1 of LINE RJ11

\* When the ON button is illuminated on the DH20/22, an "A-Lead Closure" is provided between pins 2 and 5 of the LINE and SET jacks. This connection is useful for key telephone system such as the 1A2. If you connect the DH20/22 to an extension jack of a more modern PBX, you should first check to see if those wires are used for signalling or power. If so, do not connect them to the DH20/22. You may, however, use the pin 2-5 connection to control the hookswitch on a modified PBX phone. Contact Comrex Technical Support for more information.

# SECTION 9. BLOCK DIAGRAMS

DH20

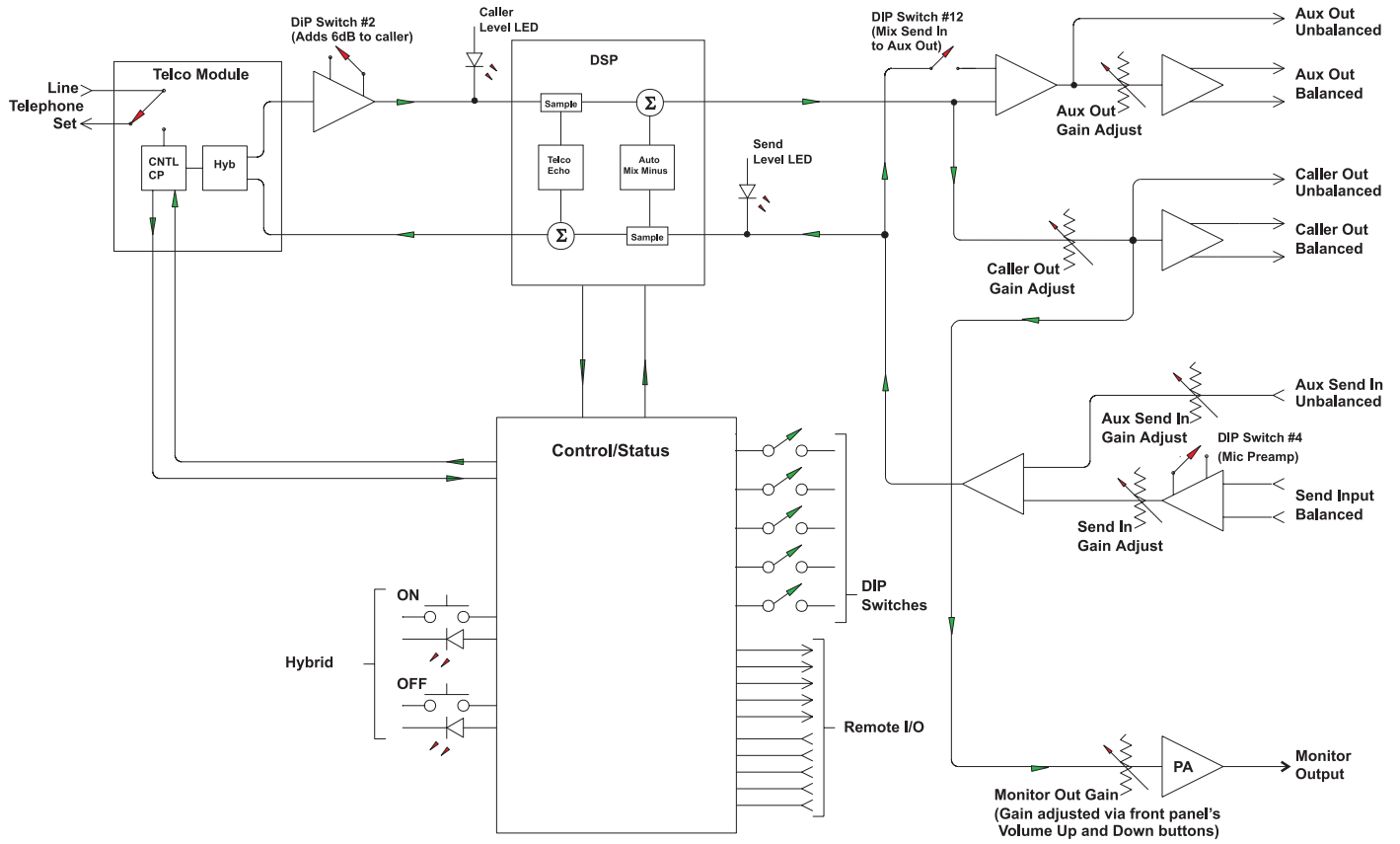

DH22

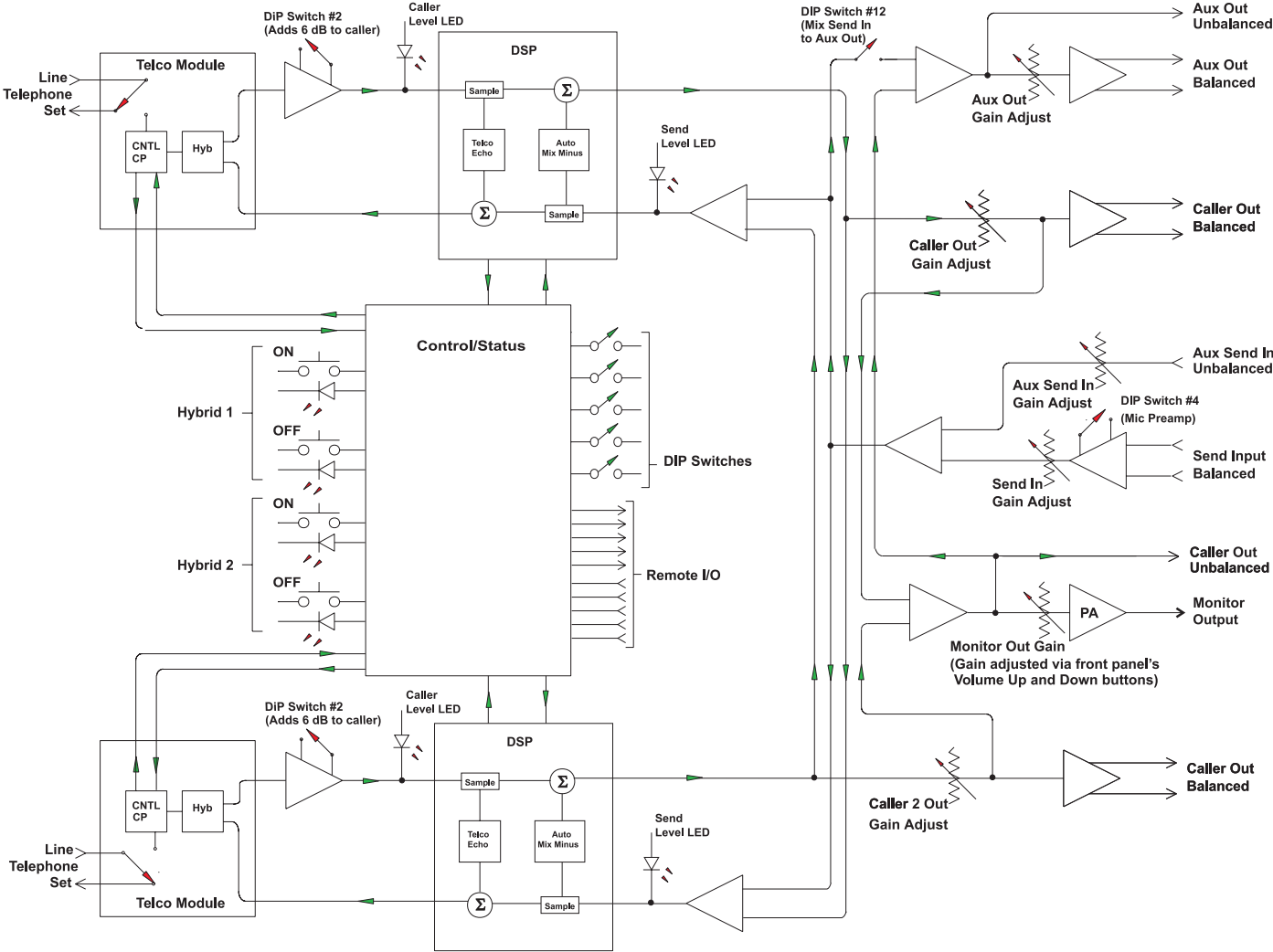

---

**SECTION 10.**

**COMPLIANCE**

*FCC PART 15 COMPLIANCE*

This equipment has been tested and found to comply with the limits for a Class B digital device, pursuant to Part 15 of the FCC rules. These limits are designed to provide reasonable protection against harmful interference when the equipment is operated in a commercial environment. This equipment generates, uses, and can radiate radio frequency energy and, if not installed and used in accordance with the instruction manual, may cause harmful interference to radio communications. Operation of this equipment in a residential area is likely to cause harmful interference, in which case the user will be required to correct the interference at his/her own expense.

Changes or modifications not expressly approved by Comrex Corporation could void the user's authority to operate the equipment.

*FCC PART 68 COMPLIANCE*

**FCC Registration Number:** FBIUSA-31573-BR-N  
**Ringer Equivalence Number (REN):** 1.1B

A label containing, among other information, the FCC registration number and Ringer Equivalence Number (REN) for this equipment is prominently posted on the top plate, near the rear of the equipment. If requested, this information must be provided to your telephone company.

**USOC Jacks:** This device uses RJ11 terminal jacks.

The REN is used to determine the quantity of devices which may be connected to the telephone line. Excessive REN's on the telephone line may result in the devices not ringing in response to an incoming call. In most, but not all areas, the sum of the REN's should not exceed five (5). To be certain of the number of devices that may be connected to the line, as determined by the total REN's, contact the telephone company to obtain the maximum REN's for the calling area.

If this equipment causes harm to the telephone network, the telephone company will notify you in advance that temporary discontinuance of service may be required. If advance notice is not practical, the telephone company will notify the customer as soon as possible. Also, you will be advised of your right to file a complaint with the FCC, if you believe it is necessary.

The telephone company may make changes in its facilities, equipment, operations, or procedures that could affect the operation of the equipment. If this happens, the telephone company will provide advance notice for you to make the necessary modifications in order to maintain uninterrupted service.

If you experience problems with this equipment, contact Comrex Corporation, 19 Pine Road, Devens, Massachusetts 01434, or by telephone at 978-784-1776 for repair and warranty information. If the trouble is causing harm to the telephone network, the telephone company may request you remove the equipment from the network until the problem is resolved.

No user serviceable parts are contained in this product. If damage or malfunction occurs, contact Comrex Corporation for instructions on its repair or return. This equipment cannot be used on telephone company provided coin service. Connection to Party Line Service is subject to state tariffs.

#### *IC COMPLIANCE*

**Ringer Equivalence Number (REN): 1.1**  
**IC Certification Number: 1970 8175 A**

NOTICE: The Industry of Canada label identifies certified equipment. This certification means that the equipment meets certain telecommunications network protective operational and safety requirements. The Department does not guarantee the equipment will operate to the user's satisfaction.

Before installing this equipment, users should ensure that it is permissible to be connected to the facilities of the local telecommunications company. The equipment must also be installed using an acceptable method of connection. In some cases, the company's inside wiring associated with a single line individual service may be extended by means of a certified connector assembly (telephone extension cord). The customer should be aware that compliance with the above conditions may not prevent degradation of service in some situations.

Repairs to certified equipment should be made Comrex Corporation. Any repairs or alterations made by the user to this equipment, or equipment malfunctions, may give the telecommunications company cause to request the user to disconnect the equipment.

Users should ensure for their own protection that the electrical ground connections of the power utility, telephone lines and internal metallic water pipe system, if present, are connected together. This precaution may be particularly important in rural areas.

*EUROPEAN COMPLIANCE*

This equipment has been approved in accordance with Council Decision 98/482/EC for pan-European single terminal connection to the public switched telephone network (PSTN). However, due to differences between the individual PSTN's provided in different countries, the approval does not, of itself, give an unconditionally assurance of successful operation on every PSTN network termination point. In the event of problems, you should contact your equipment supplier in the first instance.

Comrex Corporation of 19 Pine Road, Devens, Massachusetts 01434, U.S.A. declares that this equipment is designed to be compatible with the following networks: Austria, Belgium, Denmark, Finland, France, Germany, Greece, Iceland, Ireland, Italy, Liechtenstein, Luxembourg, The Netherlands, Norway, Portugal, Spain, Sweden, Switzerland and United Kingdom.